



GENISCO FILTER™
always on.™



Communication Line Filters

GF58270 Communication Series Filters



Product Summary

Genisco communication filters are low-pass Electromagnetic Interference and Radio Frequency Interference filters (EMI & RFI) designed to block high-frequency noise that interferes with the operation of sensitive electrical equipment.

These high performance dual circuit filters are available for both DC and AC applications including:

- Telephone
- P.A. System
- Fire Alarm-Analog
- Fire Alarm-Digital
- Relay/Thermostat
- General Communication
- Data

These standalone filters are built with a gasketed pipe to penetrate into a shielded environment (shielded rooms, screen rooms, SCIFs, secure environments, etc.) to maintain emission integrity.

Analog vs. Digital Filter Applications

Analog communication filters are generally used when a system is composed of only analog equipment. If any part of the system contains digital equipment, a digital filter may be required, as most digital systems have ground fault equipment that can be tripped by a filter on the circuit. A digital filter with a higher pass-band frequency may prevent false ground fault triggers.

*SUBJECT TO CHANGE WITHOUT NOTICE
03/28/2014*



GENISCO FILTER™
always on.™





FUNCTIONAL CHARACTERISTICS

- Voltage Ratings:
 - 24-1,000 VDC
 - 120/208 VAC (50/60 Hz)
 - 277/480 VAC (50/60 Hz)
- Temperature Rating:
 - MIL-PRF-15733
- Current Overload:
 - 140% maximum current rating
- RF Radiation:
 - Greater than 100 dB isolation
- Dielectric With-Standing Voltage:
 - 1,000 VDC (prior to installation of discharge resistors)
- Insulation Resistance:
 - MIL-PRF-15733 (prior to installation of discharge resistors)

SPECIAL FEATURES

Filters

- Factory pre-wired clean output lead provided through the pipe penetration
- Low Pass filter circuits ~ passive components which includes inductors, capacitors, resistors and optional transient suppression devices
- Manufactured and tested per applicable portions of MIL-PRF-15733
- All circuits provided in single enclosure
- Discharge resistors incorporated to eliminate potential shock hazard

Mechanical Dimensions

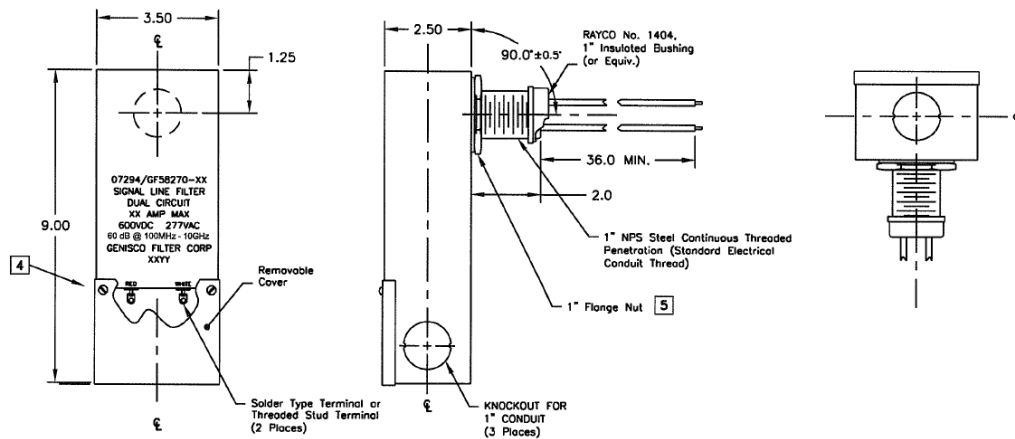

SUBJECT TO CHANGE WITHOUT NOTICE
03/28/2014

Enclosure

- Fabricated case of not less than 18 gauge cold rolled steel electro plated or painted Gray (Std. Paint Color)
- Sealed with welded and soldered seams for minimum shielding effectiveness 100 dB, 14 kHz to 18 GHz
- Threaded steel pipe penetration
- Triple knock outs provided on filter case input
- Front cover access to input terminals
- Mounting tab provided for easy wall mount options

Applicable Specifications

- Military Specifications
 - MIL-PRF-15733 General
- Military Test Methods
 - MIL-STD-202 Component Parts
 - MIL-STD-220 Insertion Loss
 - MIL-STD-285 Shielding Effectiveness
- NFPA 70/2011 National Electrical Code Standards

Available Options

- Surge Suppressors
- Alternate pipe penetration locations on the enclosure available by request.
- Custom Paint Colors (Enclosure)
- RF Secure Penetration Accessories



GENISCO FILTER™
always on.™



GF58270-XX-4 SIGNAL LINE FILTER
4 PAIR - 8 WIRE

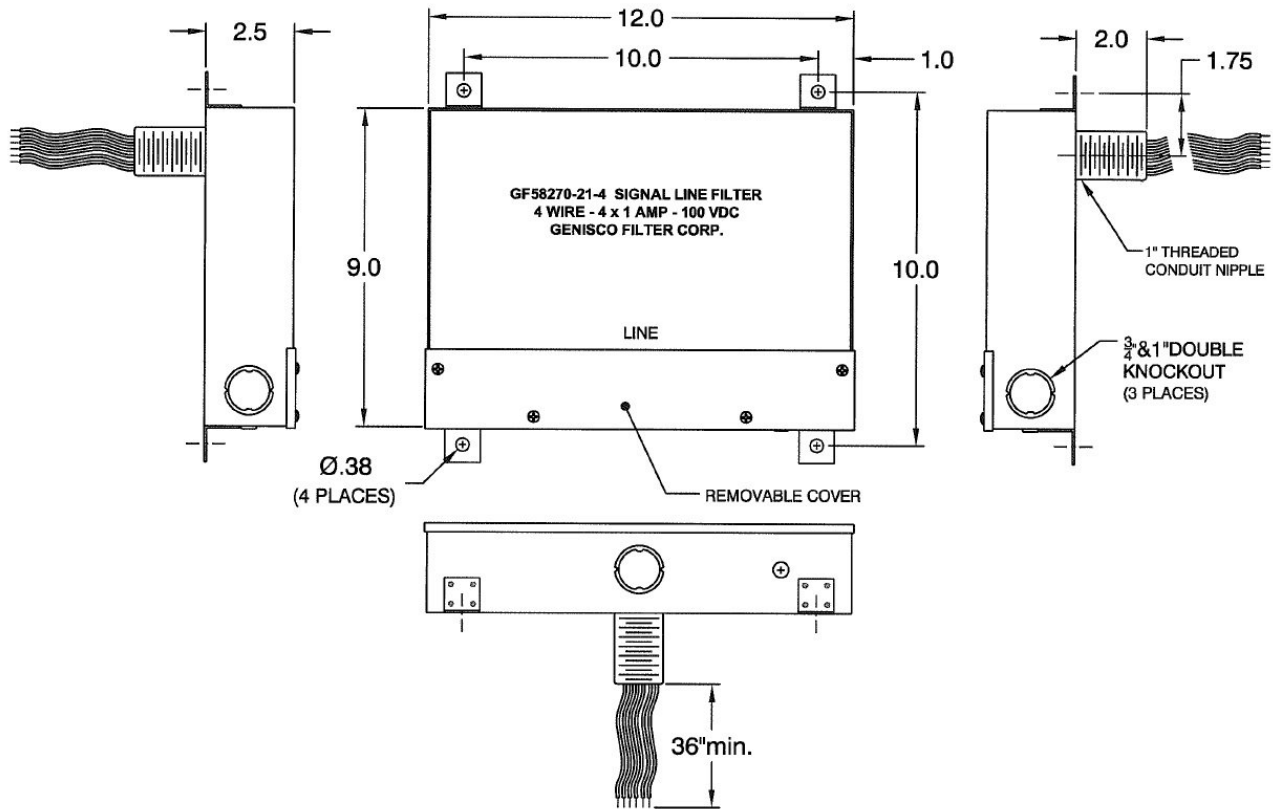



Table 1 Ordering Guide

Part #	Typical Application	Imp L-L (ohms)	Imp L-G (ohms)	Voltage max	Current max (amps)	DC Res (ohms)	Pass-Band (kHz)	Insertion Loss	Test Frequency
GF58270-1	A: Telephone	600	300	400 VDC, 125 VAC	0.5	≤ 12	0-4	≥ 100 dB	14 kHz-10 GHz
GF58270-2	A: Telephone	600	300	400 VDC, 125 VAC	0.5	≤ 12	0-4	≥ 60 dB	14 kHz-10 GHz
GF58270-3	A: Telephone	600	300	400 VDC, 125 VAC	0.4	≤ 8	0-3	≥ 100 dB	40 kHz-10 GHz
GF58270-4	A: Telephone	600	300	400 VDC, 125 VAC	0.5	≤ 6	0-4	≥ 60 dB	14 kHz-10 GHz
GF58270-5	A: P.A. Systems	16	8	100 VDC	1.5	≤ 5	0-3	≥ 100 dB	14 kHz-10 GHz
GF58270-6	A: P.A. Systems	32	16	100 VDC	1.5	≤ 5	0-3	≥ 100 dB	14 kHz-10 GHz
GF58270-7	A: Fire Alarm	64	32	400 VDC, 125 VAC	1.0	≤ 2.0	N/A	≥ 100 dB	14 kHz-10 GHz
GF58270-8	A: Fire Alarm	150	75	400 VDC, 125 VAC	1.0	≤ 1.0	N/A	≥ 100 dB	14 kHz-10 GHz
GF58270-9	A: Fire Alarm	100	50	100 VDC	4.0	≤ 1	N/A	≥ 100 dB	14 kHz-10 GHz
GF58270-10	A: Relay/ Thermostat	100	50	400 VDC, 125 VAC	0.4	≤ 1	N/A	≥ 100 dB	14 kHz-10 GHz
GF58270-11	D: General Communication	50	25	100 VDC, 30 VAC	1.0	≤ 1	0-3.5	≥ 100 dB	50 kHz-10 GHz
GF58270-12	D: General Communication	450	22.5	100 VDC, 30 VAC	0.5	≤ 2	0-3.5	≥ 100 dB	14 kHz-10 GHz
GF58270-13	D: General Communication	600	300	400 VDC, 125 VAC	0.5	≤ 6	0-4	≥ 100 dB	50 kHz-10 GHz
GF58270-14	D: General Communication	76	38	400 VDC, 125 VAC	1.0	≤ 1	0-6	≥ 100 dB	50 kHz-10 GHz
GF58270-15	D: Data (1200 Baud)	600	300	400 VDC, 125 VAC	0.4	≤ 1	0-3	≥ 100 dB	14 kHz-10 GHz
GF58270-16	D: Data (2400 Baud)	600	300	400 VDC, 125 VAC	0.4	≤ 1	0-6	≥ 100 dB	40 kHz-10 GHz
GF58270-17	D: Data (4800 Baud)	600	300	400 VDC, 125 VAC	0.4	≤ 1	0-12	≥ 100 dB	80 kHz-10 GHz
GF58270-18	D: Data (9600 Baud)	600	300	400 VDC, 125 VAC	0.5	≤ 1	0-24	≥ 100 dB	150 kHz-10 GHz
GF58270-19	D: Data (19200 Baud)	600	300	400 VDC, 125 VAC	0.5	≤ 1	0-48	≥ 100 dB	300 kHz-10 GHz
GF58270-20	D: Data (38400 Baud)	600	300	400 VDC, 125 VAC	1.0	≤ 1	0-100	≥ 100 dB	600 kHz-10 GHz
GF58270-21	D: Data / Digital Fire Alarm (56000 Baud)	600	300	400 VDC, 125 VAC	1.0	≤ 1	0-140	≥ 100 dB	1 MHz-10 GHz
GF58270-22	D: Data (128000 Baud)	124	62	400 VDC, 125 VAC	1.0	≤ 1	0-256	≥ 100 dB	5 MHz-10 GHz

* 'A:' = Analog Applications, 'D:' = Digital Applications

*Other Circuit Configurations and Current Ratings Available Upon Request • Dimensions are in Inches

SUBJECT TO CHANGE WITHOUT NOTICE
03/28/2014